

MDE Series

**Molding Power Inductors
Size 252012S**



FEATURES

- High saturation current realized by material properties and structure design.
- Low DC resistance to achieve high conversion efficiency and lower temperature rising.
- Low Profile.
- Magnetically shielded structure to accomplish high resolution in EMC protection.
- Halogen free, Lead Free, RoHS Compliance.

APPLICATION

- Generic in portable DC to DC converter line.
- Smart phone, PAD
- DC/DC converter
- Thin-type power supply module.

Dimensions: [mm]

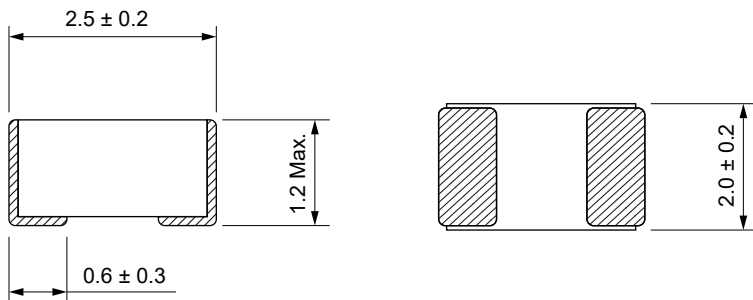

Land Pattern: [mm]

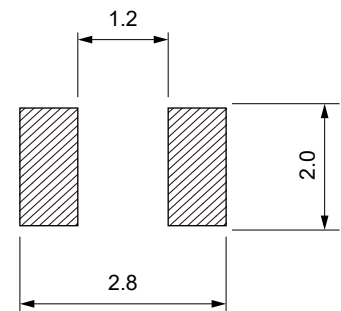

Electrical Properties:

Part No	Inductance @ 1MHz/1V (μH)	Tolerance	DC Resistance Typ. (mΩ)	DC Resistance Max. (mΩ)	Saturation Current Typ. (A)	Saturation Current Max. (A)	Temperature Rise Current Typ. (A)	Temperature Rise Current Max. (A)
MDE252012S-R47M	0.47	±20%	16	22	6.8	6.2	5.8	4.9
MDE252012S-1R0M	1.0	±20%	36	44	4.8	4.3	3.9	3.3
MDE252012S-2R2M	2.2	±20%	74	89	3.5	3.2	2.5	2.2

Operating temperature range - 40 °C to + 125 °C

Temperature rising current will cause the coil temperature approximate ΔT40 °C

Saturation current will cause to drop approximately 30 %

Typical Electrical Characteristics:

Inductance&Temp Rise VS DC Current Characteristics:

