

**MDE Series**  
Molding Power Inductors  
Size 252012



**FEATURES**

- High saturation current realized by material properties and structure design.
- Low DC resistance to achieve high conversion efficiency and lower temperature rising.
- Low Profile.
- Magnetically shielded structure to accomplish high resolution in EMC protection.
- Halogen free, Lead Free, RoHS Compliance.

**APPLICATION**

- Generic in portable DC to DC converter line.
- Smart phone, PAD
- DC/DC converter
- Thin-type power supply module.

Dimensions: [mm]

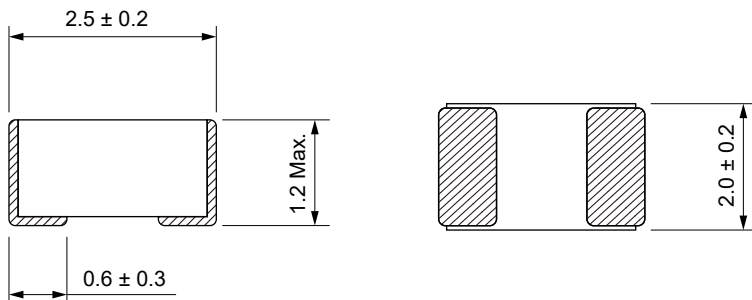

Land Pattern: [mm]

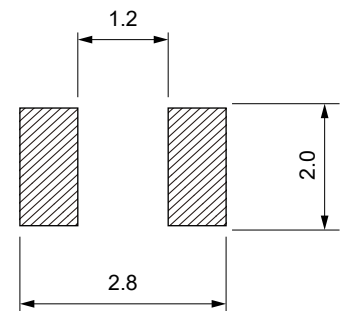

**Electrical Properties:**

Part No	Inductance @ 1MHz/1V (μH)	Tolerance	DC Resistance Typ. (mΩ)	DC Resistance Max. (mΩ)	Saturation Current Typ. (A)	Saturation Current Max. (A)	Temperature Rise Current Typ. (A)	Temperature Rise Current Max. (A)
MDE252012-R47M	0.47	±20%	21	25	5.3	4.95	4.60	4.18
MDE252012-R68M	0.68	±20%	29	35	5.0	4.63	3.70	3.36
MDE252012-1R0M	1.0	±20%	41	49	4.4	4.04	3.50	3.18
MDE252012-1R5M	1.5	±20%	64	77	3.2	2.91	2.50	2.27
MDE252012-2R2M	2.2	±20%	85	98	3.0	2.73	2.27	2.06
MDE252012-3R3M	3.3	±20%	125	150	2.1	1.80	2.00	1.80
MDE252012-4R7M	4.7	±20%	196	235	1.9	1.58	1.61	1.40

Operating temperature range - 40 °C to + 125 °C

Temperature rising current will cause the coil temperature approximate ΔT40 °C

Saturation current will cause to drop approximately 30 %

Typical Electrical Characteristics:

Inductance&Temp Rise VS DC Current Characteristics:

