

ACMA Series
Common Mode Filters For Automotive Signal Line
Size 3225



FEATURES

- Common mode filters for automotive A2B (Audio bus) C2B (Car camera bus) .
- By unique method, maintenance and L high 100μH is a product which realized high Characterization of mode conversion characteristics Scd21.
- Operating temperature range:-40 to+125 °C
- AEC-Q200 qualified.
- Quantity: 2000pcs.

APPLICATION

- CAN-BUS, FlexRay system.

Dimensions: [mm]

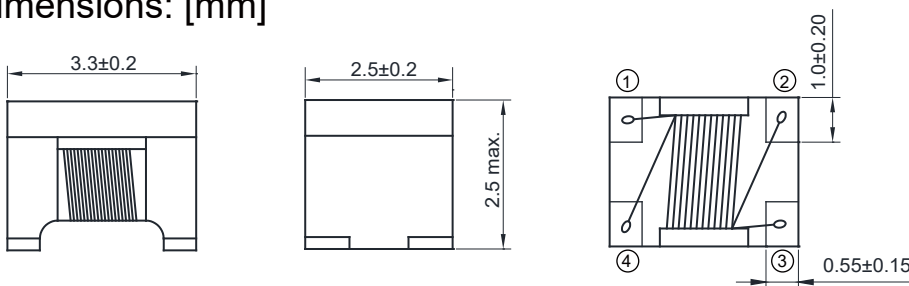

Land Pattern: [mm]

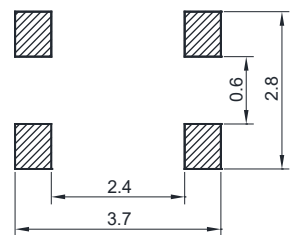

Electrical Properties:

Part No	Inductance @100KHz/0.1V (μH)	Tolerance	Rated Current Max. (mA)	DC Resistance Max. (Ω)	Rated Voltage Max. (V)	IR Min. (MΩ)
ACMA3225-101YC	100	+50/-30%	150	1.5	80	10

Typical Electrical Characteristics:

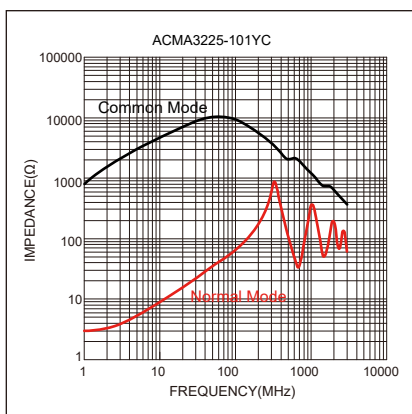

Soldering Reflow:

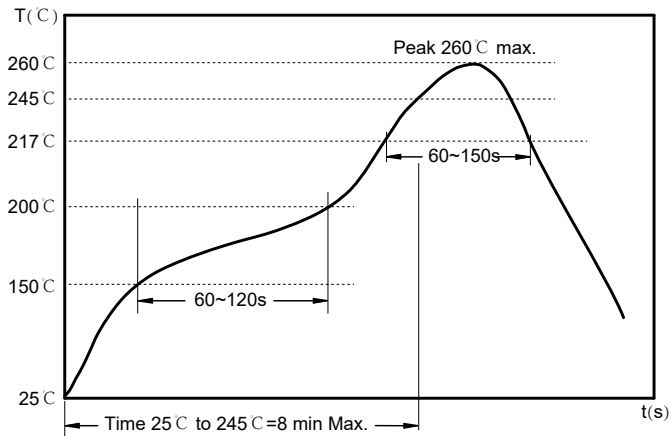

Preheat condition: 150 ~200 C / 60~120 sec.

Allowed time above 217 C : 60~150 sec.

Max temperature: 260 C .

Allowed Reflow time: 3x max.

Packaging Information:

Tape Dimension :

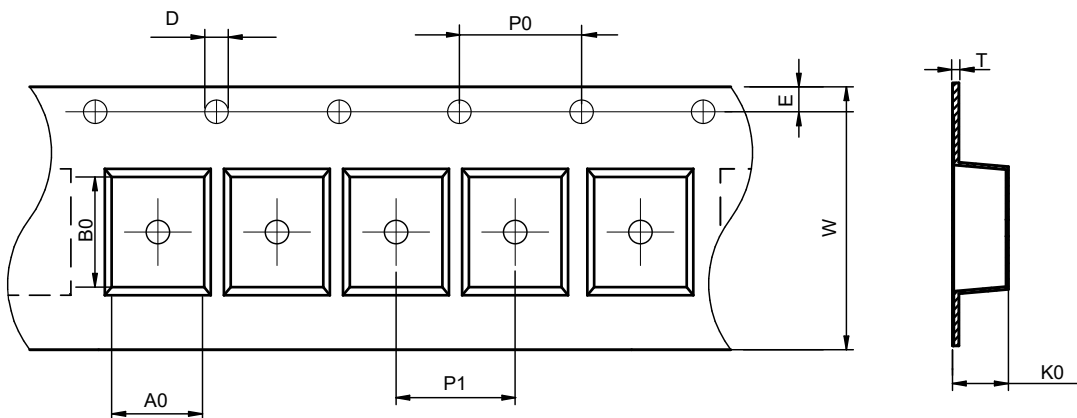

Series	A0 (mm)	B0 (mm)	D (mm)	P0 (mm)	P1 (mm)	W (mm)	K0 (mm)	E (mm)	T (mm)
ACMA3225-101YC	2.88±0.1	3.72±0.1	1.5±0.1	4.0±0.1	4.0±0.1	8.0±0.3	2.5±0.1	1.75±0.1	0.26±0.05

Peel force of top cover tape:

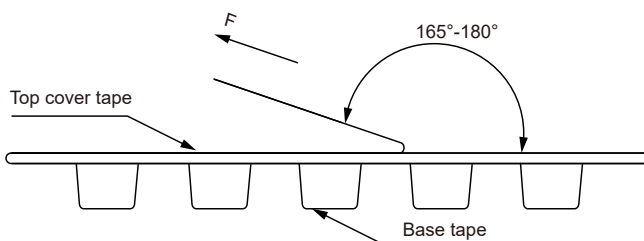

The peel force of top cover tape shall be between 0.14 to 0.78 N

Reel Dimension: [mm]

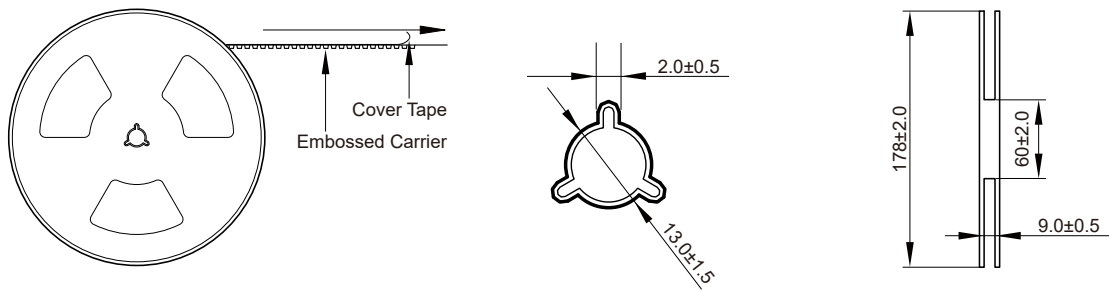

Packaging Quantity:

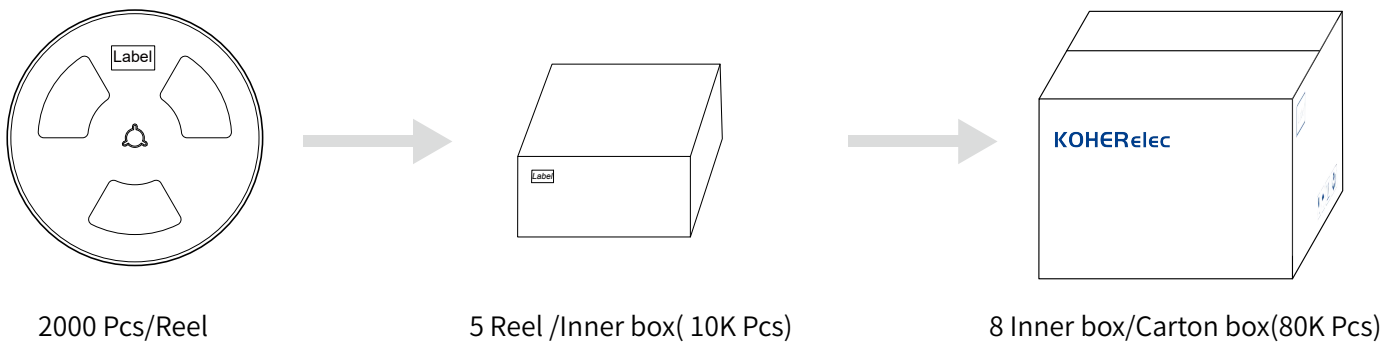

Cautions and Warnings:

Storage Conditions:

- The storage period is within 12 months after the completion of production. Be sure to follow the storage conditions (temperature: -5 to 35°C, humidity: 75% RH Max).If the storage period elapses, the soldering of the terminal electrodes may deteriorate.The warranty period is one year.
- Product should not be exposed to environment with high temperature, high humidity, dust, corrosive gas and etc.
- Products should be handled with care to avoid damage or contamination from perspiration and skin oils.
- Please always handle products carefully to prevent any damage caused by dropping down or inappropriate removing.

Operation Instructions:

- Self heating (temperature increase) occurs when the power is turned ON, so the tolerance should be sufficient for the set thermal design.
- Before soldering, be sure to preheat components.The preheating temperature should be set so that the temperature difference between the solder temperature and chip temperature does not exceed 150°C.
- Soldering corrections after mounting should be within the range of the conditions determined in the specifications.If overheated, a short circuit, performance deterioration, or lifespan shortening may occur.
- Generally, Koher might not be familiar with either customer's specific application or actual requests as customer does.As a result customer shall be responsible for checking and confirming whether Koher product with the performance described in the product specification is suitable for using in customer's particular application or not.